

Technical Reference: TR-002

Date of Issue: 13 Oct. 2006

醫療儀器的規管



*Regulation of*  
**Medical Devices**

**Summary Technical Documentation for Demonstrating  
Conformity to the Essential Principles of  
Safety and Performance of Medical Devices (STED)**

Technical Reference: TR-002



中華人民共和國

香港特別行政區政府衛生署

Department of Health

The Government of the Hong Kong Special Administrative Region  
of the People's Republic of China



## Table of Contents

1.0 Purpose.....	1
2.0 Scope.....	1
3.0 References.....	1
4.0 Definitions.....	2
5.0 Intended use of the STED and its preparation .....	2
6.0 Format for Summary Technical Documentation .....	3
6.1 Basic Format .....	3
6.2 How to Apply the Basic Format when a Pre-market Submission is not Required .....	4
6.3 How to Apply the Basic Format when a Pre-market Submission is Required .....	4
7.0 Guidance on the Elements of the STED .....	4
7.1 Relevant Essential Principles and Method Used to Demonstrate Conformity .....	4
7.1.1 General.....	4
7.1.2 Essential Principles and Evidence of Conformity .....	5
7.2 Device Description.....	5
7.2.1 General Information.....	5
7.2.2 Materials .....	6
7.2.3 Specifications .....	6
7.2.4 Other Descriptive Information.....	6
7.3 Summary of Design Verification and Validation Documents .....	6
7.3.1 General.....	6
7.3.2 Clinical Evidence .....	7
7.4 Labelling .....	7
7.5 Risk Analysis .....	7
7.6 Manufacturing Information.....	7
8.0 Enquiries .....	8
Annex A: Decision Process to Determine Whether to Use the STED .....	9
Annex B: Essential Principles Conformity Checklist.....	10
Annex C: Additional Recommendations for STEDs provided to CAB for review/approval.....	20

## **1.0 Purpose**

This guidance document provides guidance on Summary Technical Documentation (hereafter abbreviated to STED) for demonstrating conformity to the *Essential Principles of Safety and Performance of Medical Devices* (hereafter abbreviated to ‘Essential Principles’). It describes the format for a STED (see Section 6.0 below) and provides general recommendation on the content of the formatted elements (see section 7.0 below).

## **2.0 Scope**

This document applies to all the medical devices that fall within the scope of the Medical Device Administrative Control System as defined in section 3.2 of GN-01 Overview of the Medical Device Administrative Control System.

The annexes provide important supplementary information including a conformity checklist, and additional recommendations for STEDs that must be submitted to a Conformity Assessment Body for review/validation/approval, such as for a cover page, an executive summary, a sample test report format, and a sample table of contents.

This document does not recommend any new or additional technical documents above and beyond what should be created by the manufacturer to comply with existing requirements to demonstrate conformity to the Essential Principles.

The format of the STED recommended herein is based upon the goal to strive for the least burdensome means to demonstrate conformity to the Essential Principles for all classes of medical devices.

Requirements for post-market vigilance or adverse incident reporting are outside the scope of this document.

## **3.0 References**

GHTF Proposed Document: SG1/N011R17 Summary Technical Documentation for Demonstrating Conformity to the Essential Principles of Safety and Performance of Medical Devices (STED)

GN-01 Overview of the Medical Device Administrative Control System

GN-04 Conformity Assessment Framework and Conformity Assessment Bodies

## 4.0 Definitions

**Summary Technical Documentation (STED):** a summary of technical documentation held for conformity assessment purposes.

**Technical File/Technical Documentation:** documentation required to assess conformity of the medical device with the regulations.

**Essential Principles:** Essential Principles of Safety and Performance of Medical Devices

**MDCO:** Medical Device Control Office

**CAB:** Conformity Assessment Body

## 5.0 Intended use of the STED and its preparation

The STED is intended for conformity assessment purposes. The manufacturer creates the STED to demonstrate to a CAB that the subject medical device is in conformity with the Essential Principles. The STED can be a real or virtual set of documents, at the discretion of the manufacturer.

For listing of medical devices and/ or local manufacturers under the Medical Device Administrative Control System, the manufacturer is required to conduct conformity assessment according to the Essential Principles before placing the device on the Hong Kong market. In certain cases (mostly determined by the risk class of the device), the STED may need to be reviewed/ approved by a Conformity Assessment Body before the applicable device is placed on the market.

The class of the device will affect the necessary format and content of the STED and also whether or not the STED needs to be submitted to a Conformity Assessment Body for review and approval or validation before placing the device on the market. The extent of that conformity assessment and the required resulting documentation vary according to device class, increasing with higher class.

The manufacturer determines the type and detail of the total technical documentation they believe are needed to demonstrate conformity to the Essential Principles. The manufacturer holds this documentation.

As Figure 1 illustrates, the manufacturer derives the content of an STED from the total technical documentation which it has already prepared and is holding to confirm and record that the medical device is in conformity with the Essential Principles.

Further information is given in Annex A and Annex C.

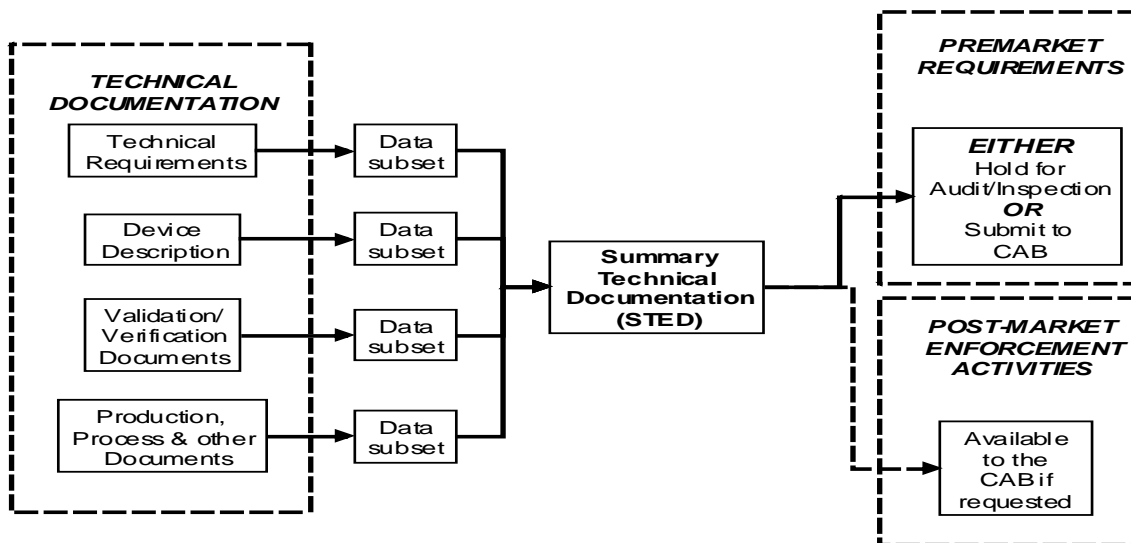

**FIGURE 1: SOURCE AND APPLICATION OF THE STED**

As Figure 1 further illustrates, the assessment of conformity to the Essential Principles by a CAB may be required before a medical device is marketed (“pre-market”), or conformity may be audited after the medical device has been marketed (“post-market”).

Medical devices that typically have a high degree of risk are those that require pre-market conformity assessment. In such cases, documentation is required to be provided to a Conformity Assessment Body for review/approval. It is intended that the STED be such documentation. For further information on STEDs provided to CAB for review/approval, see Annex C.

## 6.0 Format for Summary Technical Documentation

### 6.1 Basic Format

It is recommended that the STED be formatted as shown in the left-hand column of the table below. The right hand column indicates where expanded guidance on each recommended section can be found elsewhere in this document.

<b>Summary Technical Documentation</b>	<b>Location in this document of expanded guidance</b>
Essential Principles and evidence of conformity	Section 7.1
Device description	Section 7.2
Summary documents of design verification and validation	Section 7.3
Labelling	Section 7.4
Risk analysis	Section 7.5
Manufacturing information	Section 7.6

## **6.2 How to Apply the Basic Format when a Pre-market Submission is not Required**

The respective sections of the STED may be in any of the forms shown below, at the discretion of the manufacturer.

In consideration of the least burdensome means to demonstrate post-market conformity, the manufacturer has the following options for the STED:

Option 1: STED based on total documentation. When the total technical documentation is held in a central location and it is contained in a concise file or volume of a relatively few number of pages, then the manufacturer may choose to designate this record as also the STED for post-market assessment purposes. Ideally, this file or volume should be in the format as described in Section 6.1.

Option 2: STED based on summary documentation. The manufacturer may choose to create the STED as a summary of source documents and formatted as described in Section 6.1.

Option 3: Abbreviated STED. The manufacturer may choose to use the Table of Conformity to the Essential Principles (see Annex B) as the primary method to document conformity for post-market assessment purposes. When completed, this table will point to or reference the identity of the documents used to demonstrate conformity of each relevant Essential Principle. This method may be useful if the source documents consist of many pages and if they are held in more than one location.

Option 4: Combination STED. The manufacturer may choose to create the STED containing a combination of the above options, i.e. (1) some complete source documents, (2) summaries of some source documents, and/or (3) references to source documents.

## **6.3 How to Apply the Basic Format when a Pre-market Submission is Required**

Where (for a particular higher risk class) the STED is provided to the CAB for conformity assessment before placing the device on the market, it is recommended that the above sections be preceded by a cover page and an executive summary (see Annex C).

## **7.0 Guidance on the Elements of the STED**

### **7.1 Relevant Essential Principles and Method Used to Demonstrate Conformity**

#### **7.1.1 General**

The STED should identify the Essential Principles of Safety and Performance of Medical Devices that are applicable to the device.

The STED should identify the general method used to demonstrate conformity to each applicable Essential Principle. The methods that may be used include compliance with

recognized or other standards, state of the art or internal industry methods, comparisons to other similar marketed devices, etc.

The STED should identify the specific documents related to the method used to demonstrate conformity to the Essential Principles. For example, when the manufacturer uses international or other standards to demonstrate conformity with the Essential Principles, the STED should identify the full title of the standard, identifying numbers, date of the standard, and the organization that created the standard. When the manufacturer uses other means, such as internal standards, the STED should describe the means.

### **7.1.2 Essential Principles and Evidence of Conformity**

It is recommended that the evidence of conformity be provided in the Essential Principles Conformity Checklist (see Annex B) with supporting documentation available for review as required.

## **7.2 Device Description**

The STED should summarize or reference or contain (according to the option selected by the manufacturer in Section 6.2) the following device description data, to the extent appropriate to the complexity and risk class of the device:

### **7.2.1 General Information**

- the functional purpose of the device (intended use);
- the intended patient population(s) and medical condition(s) to be diagnosed and/or treated by the device (indications for use) and other considerations such as patient selection criteria;
- the reasonably foreseeable medical conditions for which the device is not to be used (contraindications);
- a general description of the device including its principles of operation, (capabilities, the inputs to the device and outputs);
- an explanation of any novel features;
- the accessories, and other devices or equipment which are intended to be used in combination with the device;
- the variants of the device to be marketed including, if the STED is to be provided to the CAB for review, the parameters of the range of variants;
- a general description of each of the functional parts/components of the device with labelled pictorial representations of the device (e.g. diagrams, photograph, drawing(s)), clearly indicating each part, including sufficient explanation to understand the drawings and diagrams;
- other information as needed to provide a description of the device, e.g., for an implant, a description of the anatomical location of the device in the body, attachment mechanisms for the device, including diagrams or illustrations of the implant in situ;
- comparisons to other devices to establish conformity to the Essential Principles. This could include, for example, information on previous designs of the same type of device or comparisons to other related devices.

**NOTE:** For simple, low risk devices, the above information will typically be contained in already existing sales brochures, instructions for use, etc.

## 7.2.2 Materials

- a description of the materials of the device and their physical properties to the extent necessary to demonstrate conformity with the relevant Essential Principles.

## 7.2.3 Specifications

- the functional characteristics and technical performance specifications for the device including, as relevant, accuracy, sensitivity, specificity of measuring and diagnostic devices, reliability and other factors;
- other specifications including chemical, physical, electrical, mechanical, biological, software, sterility, stability, storage and transport, and packaging to the extent necessary to demonstrate conformity with the relevant Essential Principles.

## 7.2.4 Other Descriptive Information

- other important descriptive characteristics not detailed above, to the extent necessary to demonstrate conformity with the relevant Essential Principles (for example, the biocompatibility category for the finished device).

## 7.3 Summary of Design Verification and Validation Documents

### 7.3.1 General

The STED should summarize or reference or contain (as determined by need for a submission and the option selected by the manufacturer in Section 6.2) design verification and design validation data to the extent appropriate to the complexity and risk class of the device:

Such documentation should typically include:

- declarations/certificates of conformity to the “recognized” standards listed as applied by the manufacturer; and/or
- summaries or reports of tests and evaluations based on other standards, manufacturer methods and tests, or alternative ways of demonstrating compliance<sup>1</sup>.

**EXAMPLE:** The completed Essential Principles Conformity Checklist that a recognized test standard was used as part of the method to demonstrate conformity to one Essential Principle. Section 7.0 of the STED would then include a declaration of conformity to the standard, or other certification permitted by the CAB, and a summary of the test data, if the standard does not include performance requirements.

<sup>1</sup>See Annex C4 for a **recommended** format and content of a test report.

The data summaries or tests reports and evaluations would typically cover, as appropriate to the complexity and risk class of the device:

- a listing of and conclusions drawn from published reports that concern the safety and performance of aspects of the device with reference to the Essential Principles;
- engineering tests;
- laboratory tests;
- biocompatibility tests;
- animal tests;
- simulated use;
- software validation.

A recommended test report format and content is shown in Annex C4.

### **7.3.2 Clinical Evidence**

The STED should indicate how any applicable requirements of the Essential Principles for clinical evaluation of the device have been met. Where applicable, this evaluation may take the form of a systematic review of existing bibliography, clinical experience with the same or similar devices, or by clinical investigation. Clinical investigation is most likely to be needed for higher risk class devices, or for devices where there is little or no clinical experience.

### **7.4 Labelling**

The STED should summarize or reference or contain (as determined by need for a submission and the option selected by the manufacturer in Section 6.2) the following labelling data to the extent appropriate to the complexity and risk class of the device, which is generally considered as “labelling”:

- labels on the device and its packaging;
- instructions for use;
- other literature or training materials;
- instructions for installation and maintenance;
- Any information and instructions given to the patient, including instructions for any procedure the patient is expected to perform.

### **7.5 Risk Analysis**

The STED should summarize or reference or contain (as determined by need for a submission and the option selected by the manufacturer in Section 6.2) the results of the risk analysis. This risk analysis should be based upon international or other recognized standards, and be appropriate to the complexity and risk class of the device.

### **7.6 Manufacturing Information**

The STED should summarize or reference or contain (e.g. whether submitted or according to the option selected by the manufacturer in Section 6.2) documentation related to the manufacturing processes, including quality assurance measures, which is appropriate to the complexity and risk class of the device.

## 8.0 Enquiries

Enquiries concerning this booklet and the MDACS should be directed to:

Medical Device Control Office,

Department of Health,

~~18/F, Wu Chung House~~ Rm 3101, 31/F, Hopewell Centre,

~~213 Queen's Road East~~ 183 Queen's Road East,

Wanchai, Hong Kong

Facsimile number: 3157 1286

Telephone number: ~~2961 8788~~ 3107 8484

E-mail address: [mdco@dh.gov.hk](mailto:mdco@dh.gov.hk)

## Annex A: Decision Process to Determine Whether to Use the STED

---

A person intending to introduce a new device should first determine if documentation must be provided for conformity assessment purposes before placing on the market.

Even when provision to a CAB is not required for conformity assessment purposes prior to the marketing of the device, the STED can be used for post-market conformity assessment.

See Figure 2 below for a flow chart of this process.

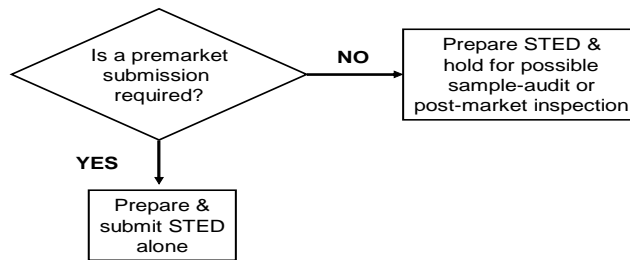

**FIGURE 2: DECISION MAKING PROCESS**

## Annex B: Essential Principles Conformity Checklist



**Essential Principles Conformity Checklist**  
**Medical Device Control Office**  
**Department of Health**  
**Medical Device Administrative Control System**

Make: \_\_\_\_\_  
 Model: \_\_\_\_\_

Clause	Essential Principle	Applicable	Method of Conformity	Identity of Specific Documents
<b>General Requirements</b>				
1.	<p>Medical devices should be designed and manufactured in such a way that, when used under the conditions and for the purposes intended and, where applicable, by virtue of the technical knowledge, experience, education or training of intended users, they will not compromise the clinical condition or the safety of patients, or the safety and health of users or, where applicable, other persons, provided that any risks which may be associated with their use constitute acceptable risks when weighed against the benefits to the patient and are compatible with a high level of protection of health and safety.</p>			
2.	<p>The solutions adopted by the manufacturer for the design and manufacture of the devices should conform to safety principles, taking account of the generally acknowledged state of the art. When risk reduction is required, the manufacturer should control the risks so that the residual risks associated with each hazard is judged acceptable. The manufacturer should apply the following principles in the priority order listed:</p> <ul style="list-style-type: none"> <li>• identify known or foreseeable hazards and estimate the associated risks arising from the intended use and foreseeable misuse,</li> <li>• eliminate risks as far as reasonably practicable through inherently safe design and manufacture,</li> <li>• reduce as far as is reasonably practicable the remaining risks by taking adequate protection measures, including alarms,</li> <li>• inform users of any residual risks.</li> </ul>			

Clause	Essential Principle	Applicable	Method of Conformity	Identity of Specific Documents
3.	Devices should achieve the performance intended by the manufacturer and be designed, manufactured and packaged in such a way that they are suitable for one or more of the functions within the scope of the definition of a medical device.			
4.	The characteristics and performances referred to in Clauses 1, 2 and 3 should not be adversely affected to such a degree that the health or safety of the patient or the user and, where applicable, of other persons are compromised during the lifetime of the device, as indicated by the manufacturer, when the device is subjected to the stresses which can occur during normal conditions of use and has been properly maintained in accordance with the manufacturer's instructions.			
5.	The devices should be designed, manufactured and packed in such a way that their characteristics and performances during their intended use will not be adversely affected under transport and storage conditions (for example, fluctuations of temperature and humidity) taking account of the instructions and information provided by the manufacturer.			
6.	The benefits must be determined to outweigh any undesirable side effects for the performances intended.			
<b>Design and Manufacturing Requirements</b>				
7.	Chemical, physical and biological properties			
7.1	<p>The devices should be designed and manufactured in such a way as to ensure the characteristics and performance referred to in Clauses 1 to 6 of the 'General Requirements'. Particular attention should be paid to:</p> <ul style="list-style-type: none"> <li>• the choice of materials used, particularly as regards toxicity and, where appropriate, flammability,</li> <li>• the compatibility between the materials used and biological tissues, cells, body fluids, and specimens, taking account of the intended purpose of the device.</li> <li>• the choice of materials used should reflect, where appropriate, matters such as hardness, wear and fatigue strength.</li> </ul>			
7.2	The devices should be designed, manufactured and packed in such a way as to minimize the risk posed by contaminants and residues to the persons involved in the transport, storage and use of the devices and to patients, taking account of the intended purpose of the product. Particular attention should be paid to tissues exposed and to the duration and frequency of exposure.			

Clause	Essential Principle	Applicable	Method of Conformity	Identity of Specific Documents
7.3	The devices should be designed and manufactured in such a way that they can be used safely with the materials, substances and gases with which they enter into contact during their normal use or during routine procedures; if the devices are intended to administer medicinal products they should be designed and manufactured in such a way as to be compatible with the medicinal products concerned according to the provisions and restrictions governing these products and that their performance is maintained in accordance with the intended use.			
7.4	Where a device incorporates, as an integral part, a substance which, if used separately, is considered to be a pharmaceutical and which is liable to act upon the body with action ancillary to that of the device, the safety, quality and usefulness of the substance should be verified, taking account of the intended purpose of the device.			
7.5	The devices should be designed and manufactured in such a way as to reduce as far as reasonably practicable and appropriate the risks posed by substances that may leach or leak from the device.			
7.6	Devices should be designed and manufactured in such a way as to reduce as far as reasonably practicable and appropriate risks posed by the unintentional ingress or egress of substances into or from the device taking into account the device and the nature of the environment in which it is intended to be used.			
8.	Infection and microbial contamination			
8.1	<p>The devices and manufacturing processes should be designed in such a way as to eliminate or to reduce as far as reasonably practicable and appropriate the risk of infection to patients, users and, where applicable, other persons. The design should:</p> <ul style="list-style-type: none"> <li>• allow easy handling,</li> </ul> <p>and, where necessary:</p> <ul style="list-style-type: none"> <li>• reduce as far as reasonably practicable and appropriate any microbial leakage from the device and/or microbial exposure during use,</li> <li>• prevent microbial contamination of the device, or specimen where applicable, by the patient, user or other person.</li> </ul>			
8.2	Where a device incorporates substances of biological origin, the risk of infection must be reduced as far as reasonably practicable and appropriate by selecting appropriate sources, donors and substances and by using, as appropriate, validated inactivation, conservation, test and control procedures.			

Clause	Essential Principle	Applicable	Method of Conformity	Identity of Specific Documents
8.3	Where a device incorporates tissues, cells and substances of non-human origin, such tissues, cells and substances should originate from animals that have been subjected to veterinary controls and surveillance adapted to the intended use of the tissues. Information on the geographical origin of the animals should be retained. Processing, preservation, testing and handling of tissues, cells and substances of animal origin should be carried out so as to provide optimal safety. In particular, safety with regard to viruses and other transmissible agents should be addressed by implementation of validated methods of elimination or inactivation in the course of the manufacturing process.			
8.4	Where a device incorporates human tissues, cells and substances, the selection of sources, donors and/or substances of human origin, the processing, preservation, testing and handling of tissues, cells and substances of such origin should be carried out so as to provide optimal safety. In particular, safety with regard to viruses and other transmissible agents should be addressed by implementation of validated methods of elimination or inactivation in the course of the manufacturing process.			
8.5	Devices labelled as having a special microbiological state should be designed, manufactured and packed to ensure they remain so when placed on the market and remain so under the transport and storage conditions specified by the manufacturer.			
8.6	Devices delivered in a sterile state should be designed, manufactured and packed in a non-reusable pack, and/or according to appropriate procedures, to ensure that they are sterile when placed on the market and remain sterile, under the transport and storage conditions indicated by the manufacturer, until the protective packaging is damaged or opened.			
8.7	Devices labelled either as sterile or as having a special microbiological state should have been processed, manufactured and, if applicable, sterilized by appropriate, validated methods.			
8.8	Devices intended to be sterilized should be manufactured in appropriately controlled (e.g. environmental) conditions.			
8.9	Packaging systems for non-sterile devices should keep the product without deterioration at the level of cleanliness stipulated and, if the devices are to be sterilized prior to use, minimize the risk of microbial contamination; the packaging system should be suitable taking account of the method of sterilization indicated by the manufacturer.			
8.10	The packaging and/or label of the device should distinguish between identical or similar products placed on the market in both sterile and non-sterile condition.			

Clause	Essential Principle	Applicable	Method of Conformity	Identity of Specific Documents
9.	Manufacturing and environmental properties			
9.1	If the device is intended for use in combination with other devices or equipment, the whole combination, including the connection system should be safe and should not impair the specified performance of the devices. Any restrictions on use applying to such combinations should be indicated on the label and/or in the instructions for use.			
9.2	<p>Devices should be designed and manufactured in such a way as to remove or reduce as far as reasonably practicable and appropriate:</p> <ul style="list-style-type: none"> <li>• the risk of injury, in connection with their physical features, including the volume/pressure ratio, dimensional and where appropriate ergonomic features;</li> <li>• risks connected with reasonably foreseeable external influences or environmental conditions, such as magnetic fields, external electrical and electromagnetic effects, electrostatic discharge, pressure, humidity, temperature or variations in pressure and acceleration;</li> <li>• the risks connected to their use in conjunction with materials, substances and gases with which they may come into contact during normal conditions of use;</li> <li>• the risks of accidental penetration of substances into the device;</li> <li>• the risk of incorrect identification of specimens;</li> <li>• the risks of reciprocal interference with other devices normally used in the investigations or for the treatment given;</li> <li>• risks arising where maintenance or calibration is not possible (as with implants), from ageing of materials used or loss of accuracy of any measuring or control mechanism.</li> </ul>			
9.3	Devices should be designed and manufactured in such a way as to minimize the risks of fire or explosion during normal use and in single fault condition. Particular attention should be paid to devices whose intended use includes exposure to or use in association with flammable substances or substances which could cause combustion.			
9.4	Devices must be designed and manufactured in such a way as to facilitate the safe disposal of any waste substances.			
10.	Devices with a diagnostic or measuring function			

Clause	Essential Principle	Applicable	Method of Conformity	Identity of Specific Documents
10.1	Devices with a measuring function, where inaccuracy could have a significant adverse effect on the patient, should be designed and manufactured in such a way as to provide sufficient accuracy, precision and stability for their intended purpose of the device. The limits of accuracy should be indicated by the manufacturer.			
10.2	Diagnostic devices should be designed and manufactured in such a way as to provide sufficient accuracy, precision and stability for their intended use, based on appropriate scientific and technical methods. In particular the design should address sensitivity, specificity, trueness, repeatability, reproducibility, control of known relevant interference and limits of detection, as appropriate.			
10.3	Where the performance of devices depends on the use of calibrators and/or control materials, the traceability of values assigned to such calibrators and/or control materials should be assured through a quality management system.			
10.4	Any measurement, monitoring or display scale should be designed in line with ergonomic principles, taking account of the intended purpose of the device.			
10.5	Wherever possible values expressed numerically should be in commonly accepted, standardised units, and understood by the users of the device.			
11.	Protection against radiation			
11.1	General			
11.1.1	Devices should be designed and manufactured and packaged in such a way that exposure of patients, users and other persons to any emitted radiation should be reduced as far as practicable and appropriate, compatible with the intended purpose, whilst not restricting the application of appropriate specified levels for therapeutic and diagnostic purposes.			
11.2	Intended radiation			
11.2.1	Where devices are designed to emit hazardous, or potentially hazardous, levels of visible and/or invisible radiation necessary for a specific medical purpose the benefit of which is considered to outweigh the risks inherent in the emission, it should be possible for the user to control the emissions. Such devices should be designed and manufactured to ensure reproducibility of relevant variable parameters within an acceptable tolerance.			
11.2.2	Where devices are intended to emit potentially hazardous, visible and/or invisible radiation, they should be fitted, where practicable, with visual displays and/or audible warnings of such emissions.			
11.3	Unintended radiation			

Clause	Essential Principle	Applicable	Method of Conformity	Identity of Specific Documents
11.3.1	Devices should be designed and manufactured in such a way that exposure of patients, users and other persons to the emission of unintended, stray or scattered radiation is reduced as far as practicable and appropriate.			
11.4	Instructions for use			
11.4.1	The operating instructions for devices emitting radiation should give detailed information as to the nature of the emitted radiation, means of protecting the patient and the user and on ways of avoiding misuse and of eliminating the risks inherent in installation.			
11.5	Ionizing radiation			
11.5.1	Devices intended to emit ionizing radiation should be designed and manufactured in such a way as to ensure that, where practicable, the quantity, geometry and energy distribution (or quality) of radiation emitted can be varied and controlled taking into account the intended use.			
11.5.2	Devices emitting ionizing radiation intended for diagnostic radiology should be designed and manufactured in such a way as to achieve appropriate image and/or output quality for the intended medical purpose whilst minimising radiation exposure of the patient and user.			
11.5.3	Devices emitting ionizing radiation, intended for therapeutic radiology should be designed and manufactured in such a way as to enable reliable monitoring and control of the delivered dose, the beam type and energy and where appropriate the energy distribution of the radiation beam.			
12.	Requirements for medical devices connected to or equipped with an energy source			
12.1	Devices incorporating electronic programmable systems, including software, should be designed to ensure the repeatability, reliability and performance of these systems according to the intended use. In the event of a single fault condition in the system, appropriate means should be adopted to eliminate or reduce as far as practicable and appropriate consequent risks.			
12.2	Devices where the safety of the patients depends on an internal power supply should be equipped with a means of determining the state of the power supply.			
12.3	Devices where the safety of the patients depends on an external power supply should include an alarm system to signal any power failure.			
12.4	Devices intended to monitor one or more clinical parameters of a patient should be equipped with appropriate alarm systems to alert the user of situations which could lead to death or severe deterioration of the patient's state of health.			

Clause	Essential Principle	Applicable	Method of Conformity	Identity of Specific Documents
12.5	Devices should be designed and manufactured in such a way as to reduce as far as practicable and appropriate the risks of creating electromagnetic interference which could impair the operation of this or other devices or equipment in the usual environment.			
12.6	Devices should be designed and manufactured in such a way as to provide an adequate level of intrinsic immunity to electromagnetic disturbance to enable them to operate as intended.			
12.7	Protection against electrical risks Devices should be designed and manufactured in such a way as to avoid, as far as possible, the risk of accidental electric shocks during normal use and in single fault condition, provided the devices are installed and maintained as indicated by the manufacturer.			
13.	Protection against mechanical risks			
13.1	Devices should be designed and manufactured in such a way as to protect the patient and user against mechanical risks connected with, for example, resistance to movement, instability and moving parts.			
13.2	Devices should be designed and manufactured in such a way as to reduce to the lowest practicable level the risks arising from vibration generated by the devices, taking account of technical progress and of the means available for limiting vibrations, particularly at source, unless the vibrations are part of the specified performance.			
13.3	Devices should be designed and manufactured in such a way as to reduce to the lowest practicable level the risks arising from the noise emitted, taking account of technical progress and of the means available to reduce noise, particularly at source, unless the noise emitted is part of the specified performance.			
13.4	Terminals and connectors to the electricity, gas or hydraulic and pneumatic energy supplies which the user has to handle should be designed and constructed in such a way as to minimize all possible risks.			
13.5	Accessible parts of the devices (excluding the parts or areas intended to supply heat or reach given temperatures) and their surroundings should not attain potentially dangerous temperatures under normal use.			
14.	Protection against the risks posed to the patient by supplied energy or substances			

Clause	Essential Principle	Applicable	Method of Conformity	Identity of Specific Documents
14.1	Devices for supplying the patient with energy or substances should be designed and constructed in such a way that the delivered amount can be set and maintained accurately enough to guarantee the safety of the patient and of the user.			
14.2	Devices should be fitted with the means of preventing and/or indicating any inadequacies in the delivered amount which could pose a danger. Devices should incorporate suitable means to prevent, as far as possible, the accidental release of dangerous levels of energy from an energy and/or substance source.			
14.3	The function of the controls and indicators should be clearly specified on the devices. Where a device bears instructions required for its operation or indicates operating or adjustment parameters by means of a visual system, such information should be understandable to the user and, as appropriate, the patient.			
15.	Protection against the risks posed to the patient for devices for self-testing or self-administration			
15.1	Such devices should be designed and manufactured in such a way that they perform appropriately for their intended purpose taking into account the skills and the means available to users and the influence resulting from variation that can reasonably be anticipated in user's technique and environment. The information and instructions provided by the manufacturer should be easy for the user to understand and apply.			
15.2	Such devices should be designed and manufactured in such a way as to reduce as far as practicable the risk of use error in the handling of the device and, if applicable, the specimen, and also in the interpretation of results.			
15.3	Such devices should, where reasonably possible, include a procedure by which the user can verify that, at the time of use, that the product will perform as intended by the manufacturer.			
16.	Information supplied by the manufacturer			
16.1	Users should be provided with the information needed to identify the manufacturer, to use the device safely and to ensure the intended performance, taking account of their training and knowledge. This information should be easily understood.			
17.	Performance evaluation including, where appropriate, clinical evaluation			

Clause	Essential Principle	Applicable	Method of Conformity	Identity of Specific Documents
17.1	All data generated in support of performance evaluation should be obtained in accordance with the relevant requirements applicable in the countries where the data are gathered.			
17.2	Clinical investigations on human subjects should be carried out in accordance with the spirit of the Helsinki Declaration. This includes every step in the clinical investigation from first consideration of the need and justification of the study to publication of the results.			

I confirm that I have neither amended the wording in this form, nor otherwise altered the form in any material manner, apart from filling in the blanks.

I declare that the information provided in this form is accurate and correct and the device conforms to all the applicable requirements stipulated above.

Signature: \_\_\_\_\_

Name: \_\_\_\_\_

Position: \_\_\_\_\_

The Applicant (Local Responsible Person): \_\_\_\_\_

Date: \_\_\_\_\_

## **Annex C: Additional Recommendations for STEDs provided to CAB for review/approval**

---

### **C.1 General**

When conformity assessment by a CAB to the Essential Principles is required before a device is marketed (“pre-market”), then the manufacturer should provide the STED in the format described in Section 6.0 (see also Annex A for deciding when to use the STED).

Even when conformity assessment by a CAB to the Essential Principles is not required before a device is marketed, the CAB may still request that the manufacturer demonstrate conformity after it is marketed (“post-market”). Post-market assessment may be carried out by means of providing the STED to the CAB or by audit of the STED by the CAB at the manufacturer’s facilities. Special circumstances may necessitate the examination of documentation supporting the STED.

**EXAMPLE:** For a Class II device the CAB may request that the manufacturer provide documentation demonstrating conformity to the Essential Principles after the device is marketed. The manufacturer may provide documentation in any one of the four forms described as Options 1 – 4 in Section 6.0 unless the CAB stipulates the need for a specific form or documents.

### **C.2 Cover Page**

A covering letter should be at the beginning of a STED provided to CAB for review/approval. The covering letter will explain the purpose of the STED.

### **C.3 The Executive Summary**

An executive summary provides an overview of the medical device and helps to orient the reviewer. Where the STED is provided to CAB for review/approval, the executive summary may be included in a cover page or it may be a separate section of the STED.

It is recommended that the executive summary include at least the following information:

- an overview of the STED, e.g., introductory descriptive information on the medical device, the intended uses and indications for use of the medical device, any novel features and a synopsis of the content of the STED; and
- a commercial marketing history of the device including, for example, the countries in which the device is sold, the intended uses and indications in labelling, status of any pending requests for market clearance, important safety or performance related information such as recalls and adverse effects encountered.

#### **C.4 Recommended Test Report Format**

A test report should include, as applicable:

- i) Report title and other identifying information.
- ii) Name and address of facility performing the test.
- iii) Name of the responsible person involved.
- iv) Dates that testing was initiated and completed.
- v) Study plan, results, and conclusions, including, for example:
  - the study objective and test hypothesis;
  - a description of the test system used including relevant specifications (a diagram may be helpful);
  - a description of the differences between the test samples and final specifications, if any;
  - deviations from test plan, if any;
  - a comprehensive summary of the data in the form and manner specified by the CAB which will allow an independent assessment;
  - statistical evaluation of the test results, where appropriate;
  - bibliography of all references pertinent to the report.